

VETO 220

TEST RESULTS OF THE BOILER TESTING ACCORDING TO EN 303-5:2012

Requested by:

Veljekset Ala-Talkkari Oy



Customer/ Requested by Veljekset Ala-Talkkari Oy
Hannu Ala-Talkkari
Hellanmaantie 619
62130 Hellanmaa

Order email by Hannu Ala-Talkkari 12 November 2016

Contact person at VTT **VTT EXPERT SERVICES LTD**
Aimo Kolsi
Koivurannantie 1
Jyväskylä, P.O. Box 28
Finland
Tel. +358 (0) 20 722 2571
Fax +358 (0) 14 617 058
aimo.kolsi@vtt.fi

Tested appliance VETO 220

Testing has been undertaken according to the standard EN 303-5:2012 – Part 5: Heating boilers for solid fuels, hand and automatically stoked, nominal heat output of up to 500 kW- Terminology requirements, testing and marking.

The standard EN 303-5:2012 is listed on VTT's qualification certificate as an Accredited Laboratory.

Appliance description

VETO 220 is a wood chip boiler equipped with a flue gas dust removal appliance.

Photographs of the test arrangement are presented in appendix 1. Technical drawings of the tested appliance are given in appendix 2.

Test arrangement

Testing has been carried out at the boiler test laboratory of JAMK University of Applied Sciences under supervision of VTT Expert Services Ltd.

Testing

The appliance construction was assessed against the requirements of Clause 4.1 of EN 303-5:2012. The appliance performance was assessed against the requirements of Clause 4.2 in accordance with the test method requirements and additional performance and safety requirements for the appliance given in Clause 5 of EN 303-5:2012.

The performance type testing consisted of a nominal heat output test and a partial heat output test. The CO₂-, O₂-, CO-, OGC- and NO_x-concentrations, as well as the flue gas temperature and dust concentrations were

measured at both heat outputs. The CO₂-, O₂-, CO- and NO_x-concentrations were measured from dry flue gases and OGC-concentration (concentration of total organic carbon) from moist flue gas at about 180 °C. Concentrations are presented in % or ppm (= part per million; for example 10000 ppm = 1%) and in mg/Nm³ of dry flue gas, as well as converted to 10% and 13% of oxygen. Emissions are presented in mg/MJ.

Total efficiency was calculated based on measured boiler output and fuel consumption and its properties. Surface temperatures of the boiler and its operating components were also measured.

Particulate measurement was carried out using gravimetric method directly from flue gases. The measurement device was manufactured by the German company Paul Gothe following the method VDI 2066 and the standard EN 13284-1. The first filter is a thimble filter and the other filter a plain filter having diameter of 45 mm. Both filters are inside the heater that is kept in 140 °C temperature.

Test fuel properties

Testing was carried out using wood chips. A representative sample was taken from the fuel batch for analysis and it was analysed in the accredited laboratory of Labtium Oy (T025 by Finas Oy) in Jyväskylä. The fuel moisture was analysed also by Labtium Oy. The properties of the test fuel are given in table 1.

Table 1. Test fuel properties.

Nominal heat output test	unit	Wood chip
Moisture content	% (wet basis)	23.3
Calorific value of DS	MJ/kg	18.49
Calorific value as received	MJ/kg	13.61
Partial heat output test		
Moisture content	% (wet basis)	21.2
Calorific value of DS	MJ/kg	18.49
Calorific value as received	MJ/kg	14.05
Ash content (550 °C)	m-% of DM	0.3
Carbon content	m-% of DM	49.4
Hydrogen content	m-% of DM	6.2
Nitrogen content	m-% of DM	0.20

Test results

Measured and calculated results of the nominal heat load test are presented in Table 2 and of the partial heat load test in Table 3. Results are averages of the total burning period.

Table 2. Measured and calculated results of *the nominal heat load test*. All concentrations are given in dry flue gas.

4 April 2017	Unit	Result
Test period	hour	6.00
Temperature of out flow water	°C	79.5
Temperature of return water	°C	60.0
Ambient temperature	°C	23.3
Amount of fuel burned	kg	371.0
Energy in fuel	kWh	1403
Energy to water circuit	kWh	1321
Boiler efficiency	%	94.1
Boiler output	kW	220.2
Electrical consumption	W/h	1297
Under pressure in the stack	Pa	-7.4
Flue gas temperature	°C	95.2
CO ₂ concentration	%	13.9
O ₂ concentration	%	6.6
CO concentration	ppm	30
CO concentration	ppm (at 10 % O ₂)	23
CO concentration	mg/Nm ³ (at 10 % O ₂)	29
CO concentration	mg/Nm ³ (at 13 % O ₂)	21
CO emission	mg/MJ	14
OGC concentration	ppm	0
OGC concentration	mg org C/m ³ (at 10 % O ₂)	0
OGC concentration	mg org C/m ³ (at 13 % O ₂)	0
OGC emission	mg org C/MJ	0
NO _x concentration	ppm	111
NO _x concentration	ppm (at 10 % O ₂)	85
NO _x concentration	mg/Nm ³ as NO ₂ (at 10 % O ₂)	174
NO _x concentration	mg/Nm ³ as NO ₂ (at 13 % O ₂)	127
NO _x emission	mg/MJ as NO ₂	85
Particulate concentration		
- measurement 1	mg/Nm ³	35
- measurement 2		40
- measurement 3		36
- measurement 4		34
Average particulate concentration	mg/Nm ³ (at 10 % O ₂)	28
Average particulate concentration	mg/Nm ³ (at 13 % O ₂)	20
Particle emission	mg/MJ	14

Table 3. Measured and calculated results of *the partial heat load test*. All concentrations are given in dry flue gas.

28 March 2017	Unit	Result
Test period	hour	6.00
Temperature of out flow water	°C	78.8
Temperature of return water	°C	59.8
Ambient temperature	°C	23.9
Amount of fuel burned	kg	109.0
Energy in fuel	kWh	425.5
Energy to water circuit	kWh	385.4
Boiler efficiency	%	90.6
Boiler output	kW	64.2
Electrical consumption	W	565
Under pressure in the stack	Pa	-11.2
Flue gas temperature	°C	59.9
CO ₂ concentration	%	9.5
O ₂ concentration	%	11.0
CO concentration	ppm	578
CO concentration	ppm (at 10 % O ₂)	636
CO concentration	mg/Nm ³ (at 10 % O ₂)	795
CO concentration	mg/Nm ³ (at 13 % O ₂)	578
CO emission	mg/MJ	387
OGC concentration	ppm	4
OGC concentration	mg org C/m ³ (at 10 % O ₂)	7
OGC concentration	mg org C/m ³ (at 13 % O ₂)	5
OGC emission	mg org C/MJ	3
NO _x concentration	ppm	65
NO _x concentration	ppm (at 10 % O ₂)	72
NO _x concentration	mg/Nm ³ as NO ₂ (at 10 % O ₂)	147
NO _x concentration	mg/Nm ³ as NO ₂ (at 13 % O ₂)	107
NO _x emission	mg/MJ as NO ₂	72
Particulate concentration	mg/Nm ³	
- measurement 1		16
- measurement 2		20
- measurement 3		19
- measurement 4		18
Average particulate concentration	mg/Nm ³ (at 10 % O ₂)	20
Average particulate concentration	mg/Nm ³ (at 13 % O ₂)	15
Particle emission	mg/MJ	10

Surface temperatures

Hottest points of the boiler *)	Temperature	Exceeding ambient room temperature by
	°C	K
Front	34	11
Back	35	12
Right side	36	13
Left side	40	17
Top	37	14
Bottom	Not measured ¹⁾	Not measured

*) boiler operating doors excluded

Surface temperatures were measured using the infrared camera ThermaCAM™ E2 and K-Type thermocouple. Temperature of the surrounding was 23.3 °C. Temperatures of the boiler surface did not exceed the maximum allowed temperature according to the standard which is $23.3 + 60 = 83.3$ °C.

More detailed surface temperature measurements are presented in appendix 3.

¹⁾ Manufacturer declares that the boiler is to be installed on non-combustible base.

Summary

The VETO 220 boiler met construction requirements detailed in clause 4.2 of EN 303-5:2012.

The VETO 220 boiler met the safety requirements detailed in clause 5 of EN 303-5:2012.

The VETO 220 boiler met the performance requirements detailed in clause 4.4 of EN 303-5:2012.

The mean carbon monoxide emission, calculated at 10% oxygen content, is below the maximum limit value of 500 mg/m³ for the best class 5 specified in clause 4.4.7 of EN 303-5:2012.

The mean organic gaseous compounds (OGC) content, calculated at 10% oxygen content, is below the maximum limit value of 20 mg/m³ for the best class 5 specified in clause 4.4.7 of EN 303-5:2012.

The mean particulate concentration, calculated at 10% oxygen content, is below the maximum limit value of 40 mg/m³ for the best class 5 specified in clause 4.4.7 of EN 303-5:2012.

The mean particulate concentration at partial heat output, calculated at 10% oxygen content, was 20 mg/m³ at 10% O₂.

The measured total efficiency at nominal heat output was 94.1 % and exceeded the requirement of not less than 89.3 % for the best class 5 specified in clause 4.4.2 of EN 303-5:2012.

Measured flue gas temperature at nominal heat output was 95 °C and was less than 160 K above the test room temperature. The manufacturer shall make recommendations regarding the flue installation in order to ensure sufficient draught and to prevent sooting up of the chimney and condensation.

The appliance operating instructions supplied by the manufacturer satisfied the requirements for the appliance operating instructions as detailed in Clause 8 of EN 303-5:2012.

Jyväskylä, 10 April 2017



Aimo Kolsi
Product Manager



Markus Kivelä
Expert



Appendices 3 pieces

Distribution	Customer	Original
	VTT / Archive	Original



VETO 220 boiler

Figure 1. Photograph 1 of the tested appliance.



Flue gas dust removal appliance

Figure 2. Photograph 2 of the tested appliance.

Appendix 2

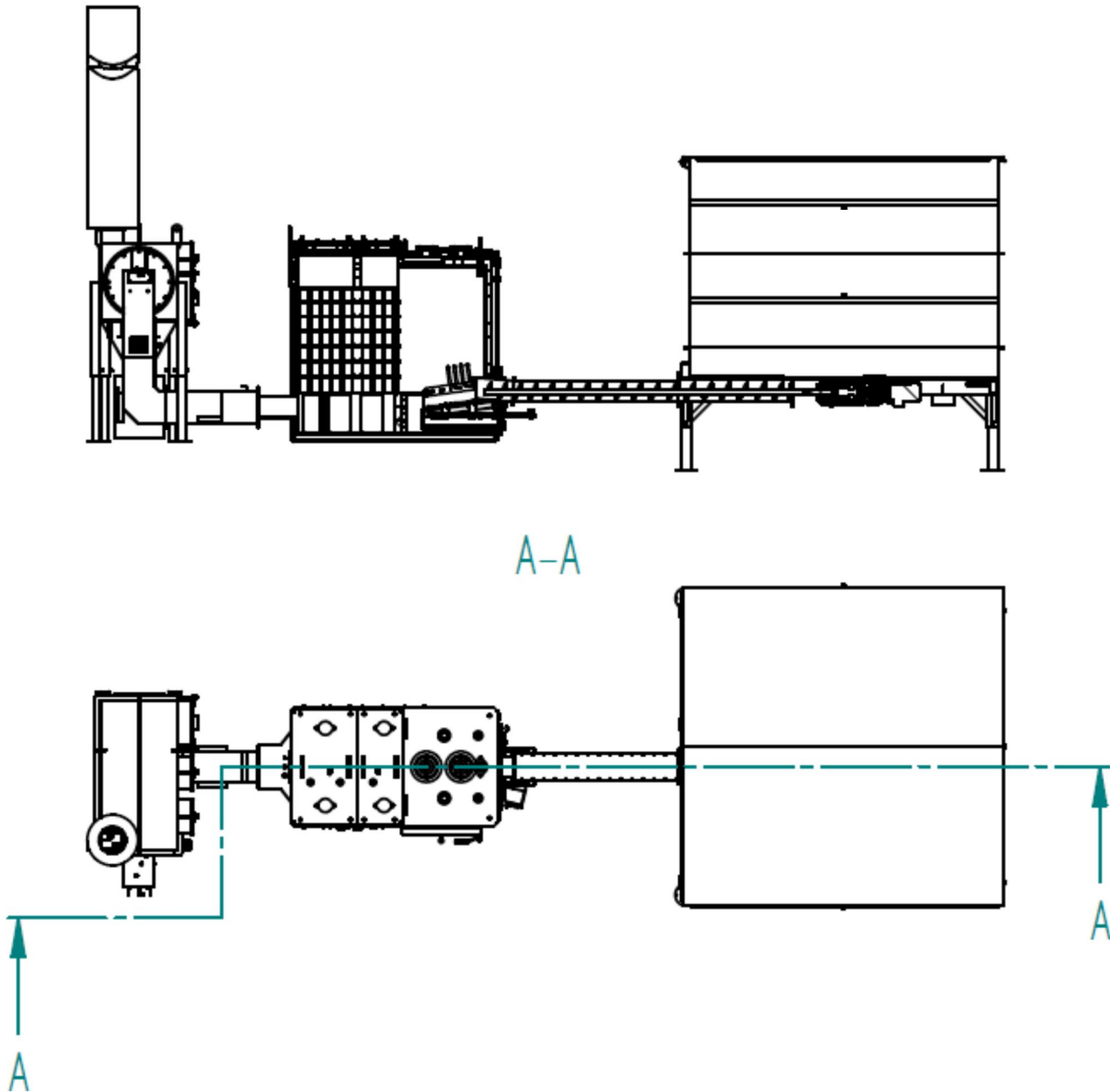

Basic principle of VETO 220 boiler

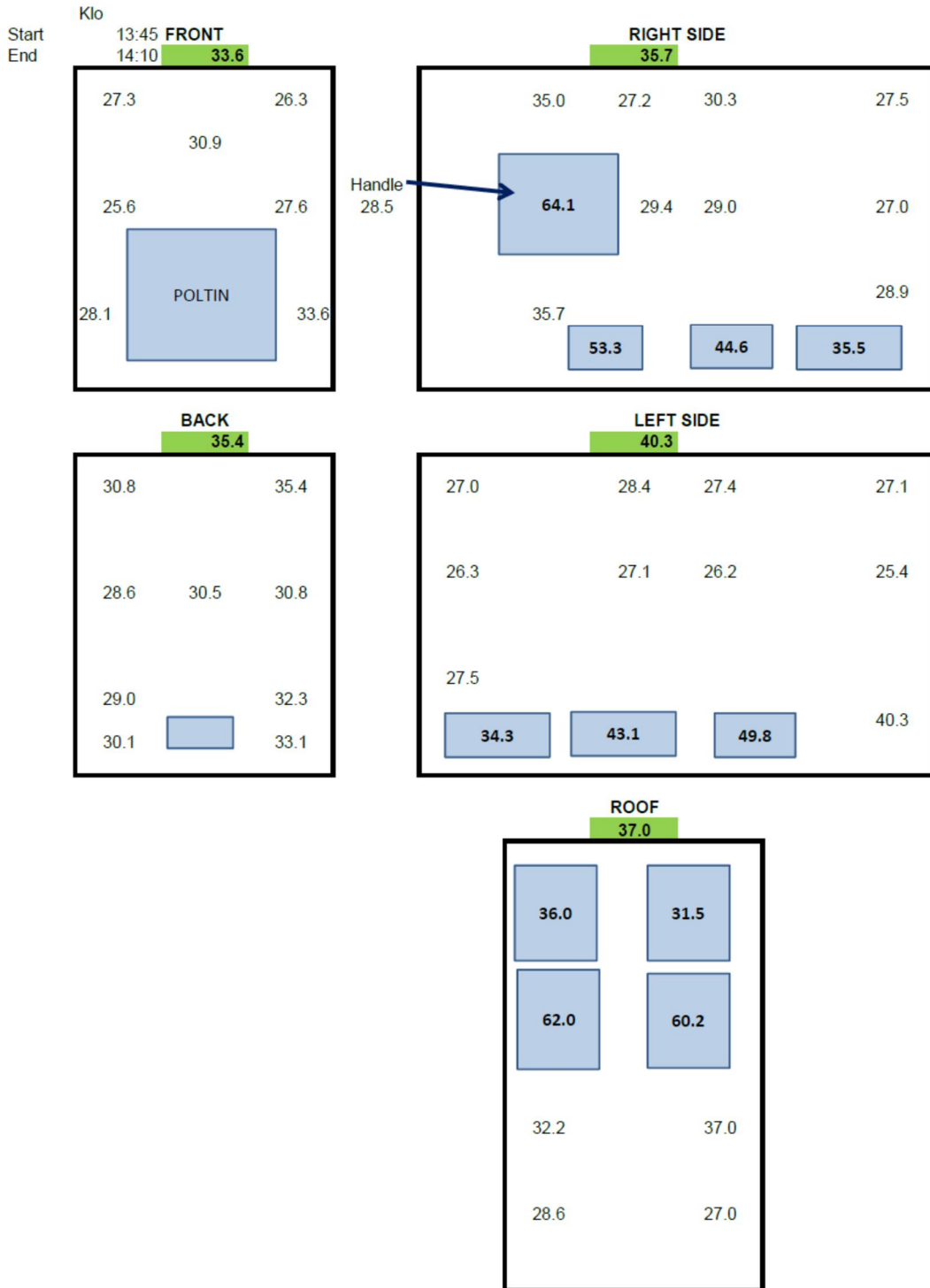

Figure 3. More detailed surface temperature measurements.